

These are my notes to fit an instrument Cluster with a tachometer into a MK2 Escort that didn't have one.

From this,

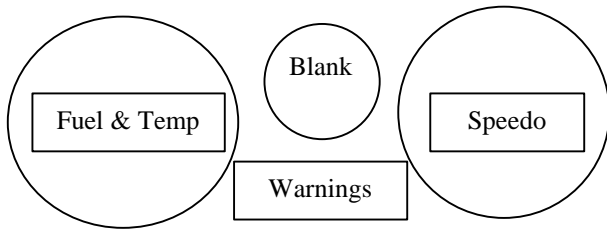

To This

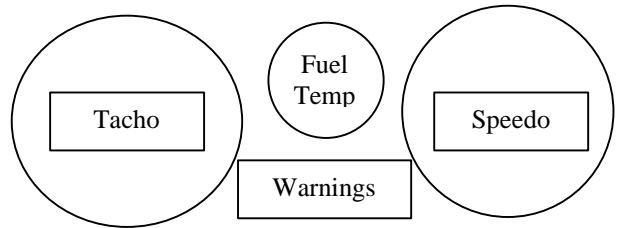

The wire from the coil already existed on my car (but was not connected to the aftermarket coil and just needed to be connected.)

The loom that connects to the back of the instrument gauge has 3 plugs.

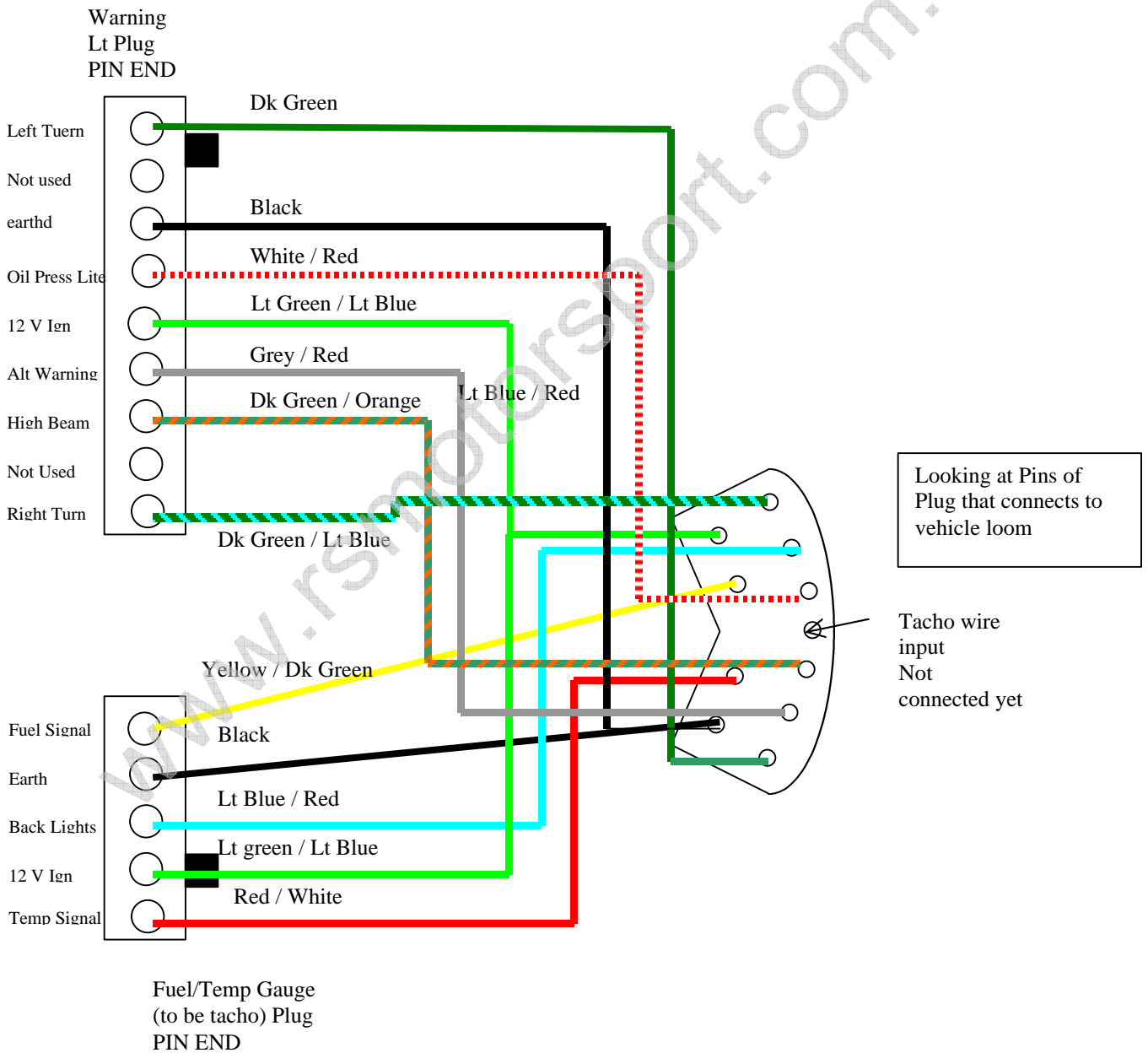

Change the wires in the loom around to the diagram below by carefully removing the pins. They will bend out of shape and need to be bent back a bit before re-inserting them in there new home. The 11 pin plug to the main loom has a red insert that locks all of the pins into it – this insert need to be clipped out first before adding the pins into it. I stole a wire from another loom to connect up the tacho pin.

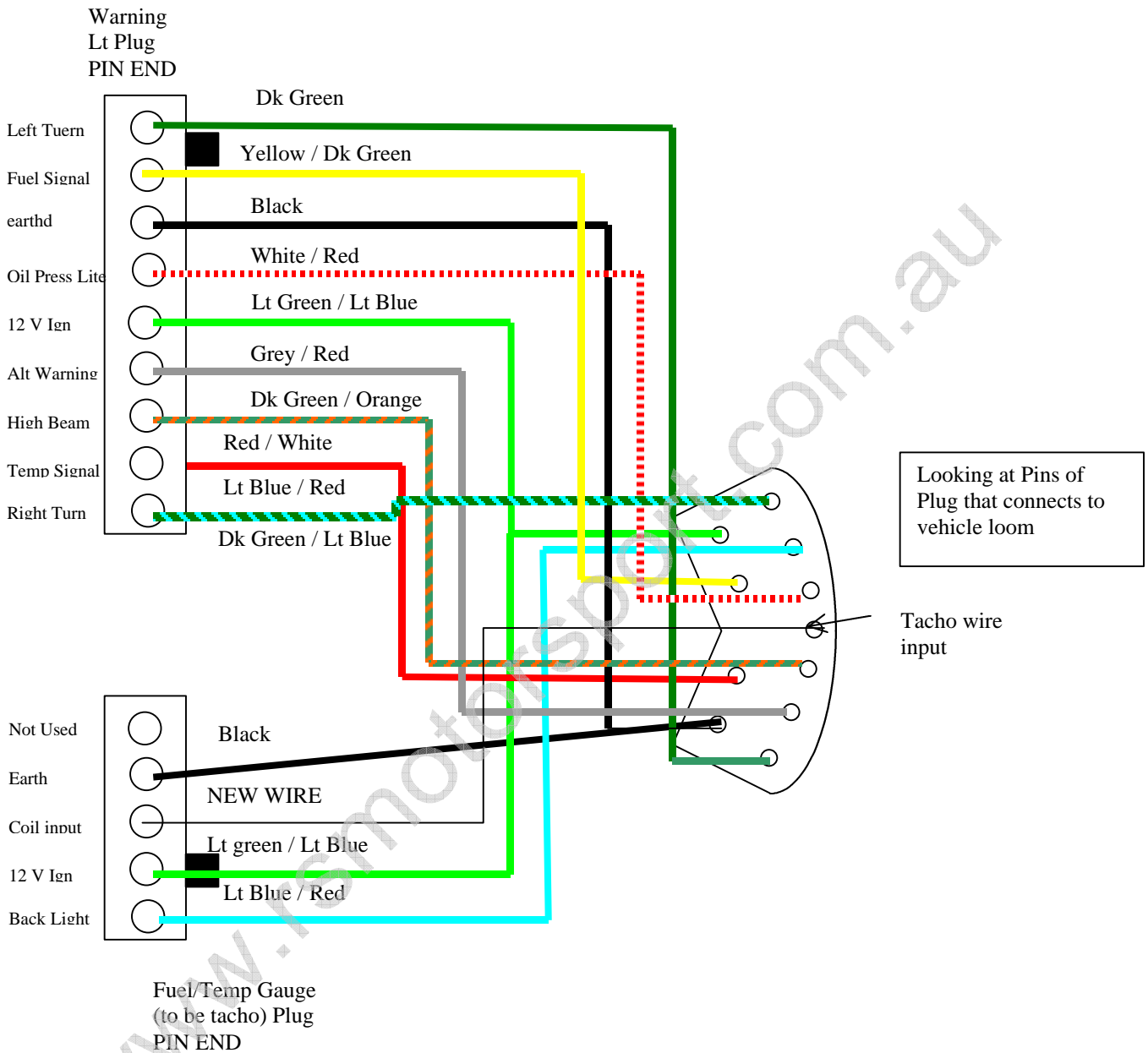

I also added an extra light into the group (my instrument cluster came without the backlights!!) so that there were 4, 2 for tacho and two for speedo.

Hope that this helps you out, let me know if I have made any mistakes.

Kris
 chrisw@birrana.com.au