

BOD FLA VIEW

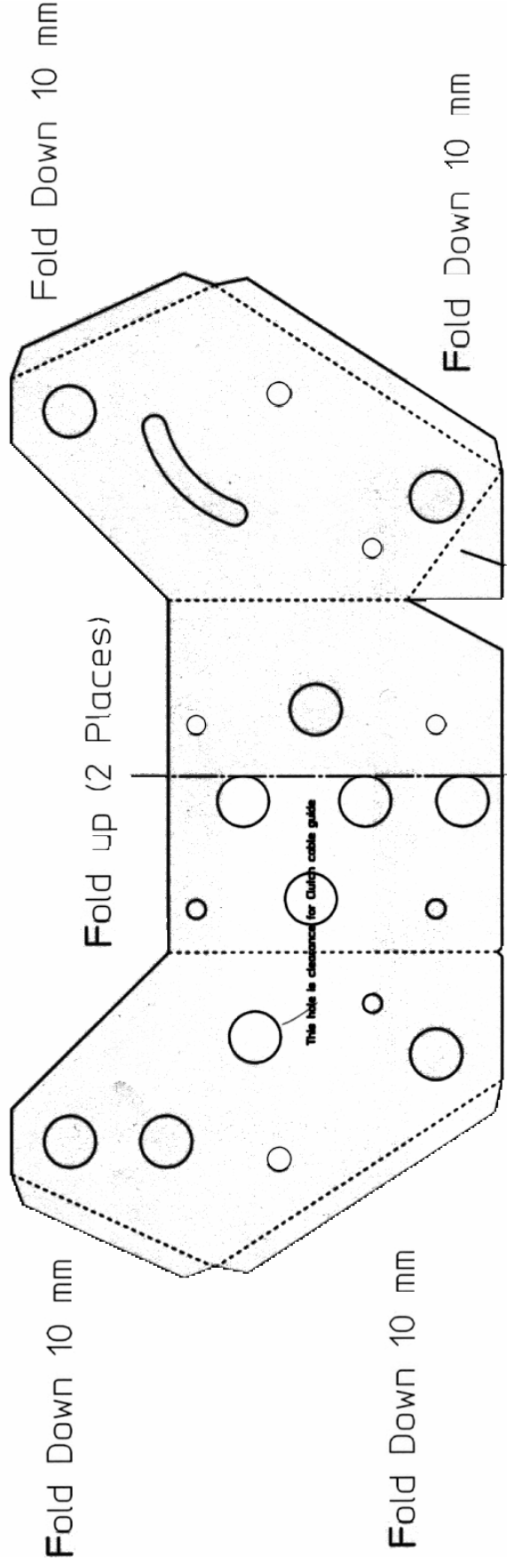

Fold Down 10 mm

Fold up (2 Places)

Fold Down 10 mm

Fold Down 10 mm

Fold Down 10 mm

Final fold by hand (hammer) clear wheel arch

CYLINDER MOUNTS AND PEDAL STOPS

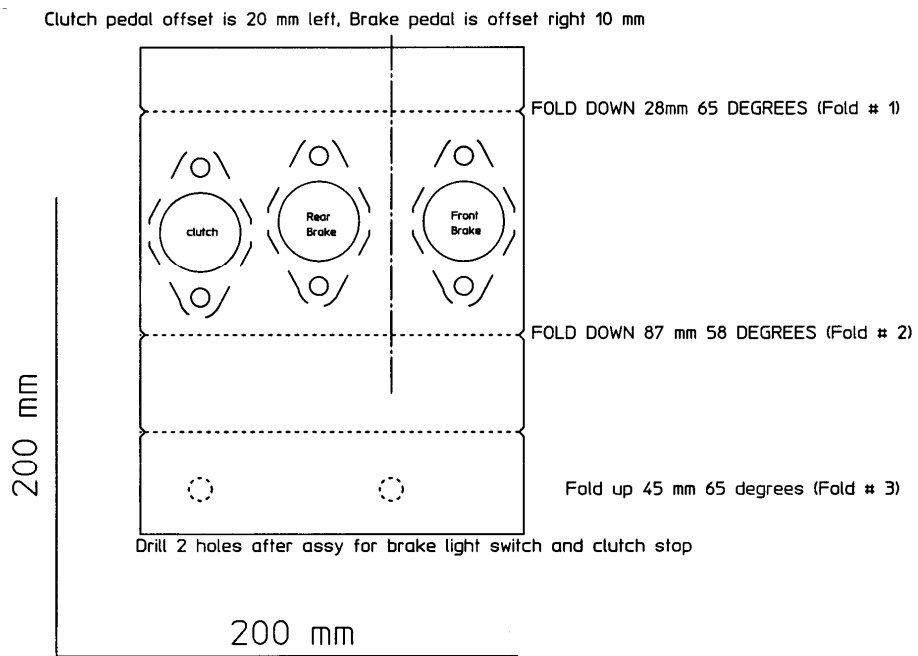

www.rsmotorsp

BODY SIDE VIEW

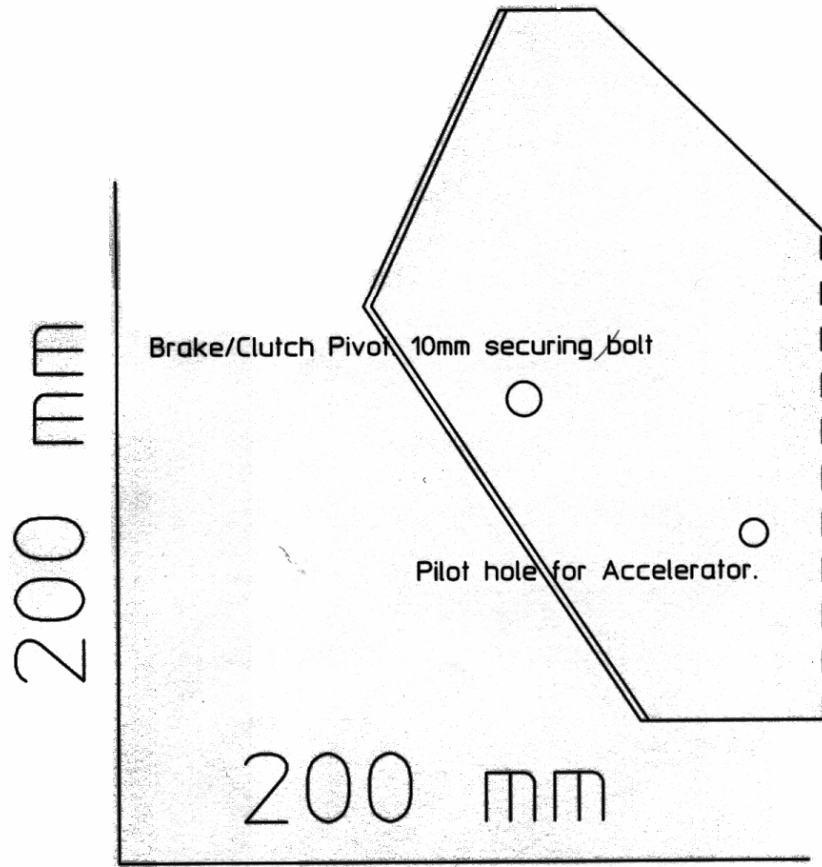

www.i

BRAKE LAYOUT

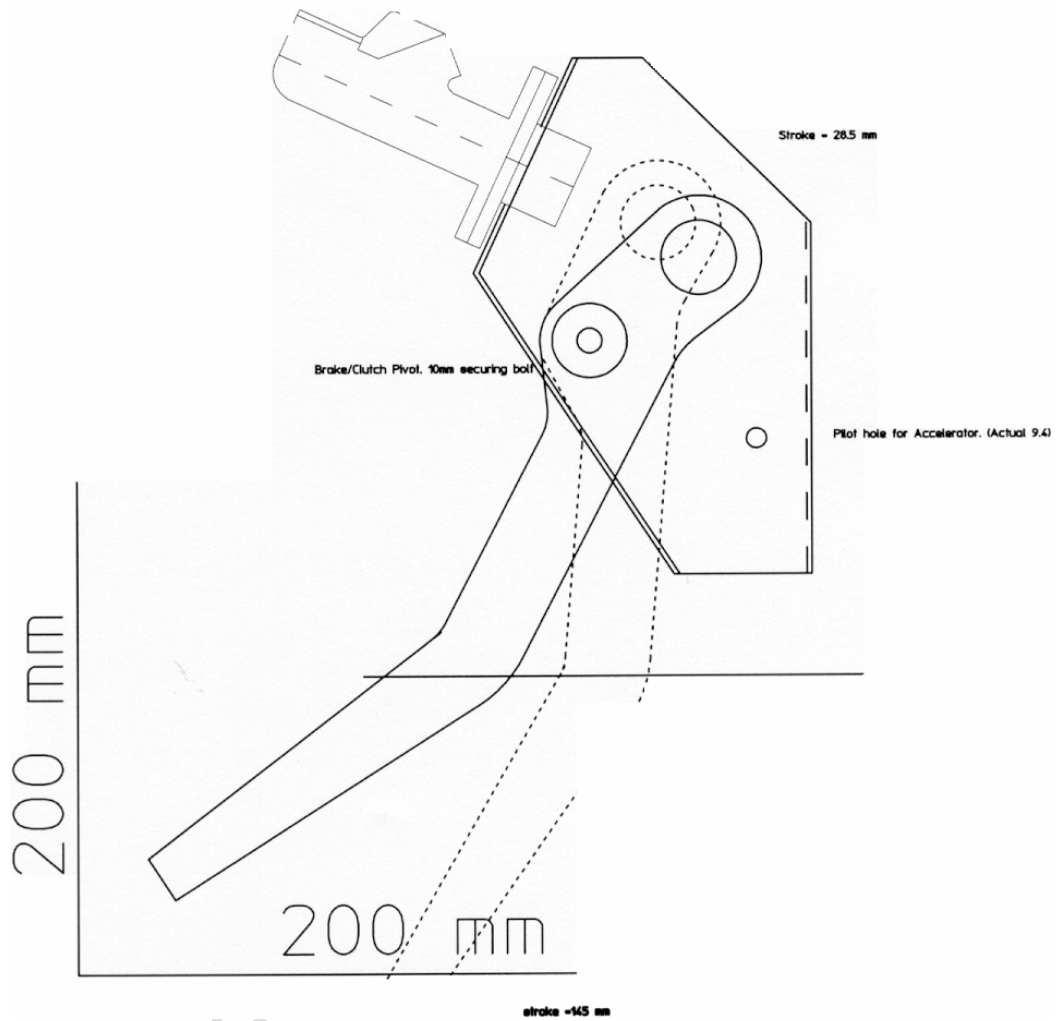

BRAKE PEDAL

